

TECHNICAL REVIEW

No. 2 — 1976

Contents

Free-Field Response of Sound Level Meters by P. Hedegaard	3
High Frequency Testing of Gramophone Cartridges using an Accelerometer by O. B. Sørensen	25
News from the Factory	35

Free-Field Response of Sound Level Meters

by

P. Hedegaard

ABSTRACT

When measuring the directional and frequency response characteristics of sound level meters, the far field reflections from the walls of the anechoic chamber as well as the near field reflections from the sound level meter body and the supporting structure are inevitable. In this article the use of warble tones, instead of pure tones, shows how the far field reflections are eliminated and how the reflections from the sound level meter body affect the directional and frequency characteristics.

SOMMAIRE

Quand on mesure les caractéristiques directionnelles et la réponse en fréquence des sonomètres, les réflexions dans le champ éloigné sur les parois de la chambre sourde, et les réflexions dans le champ proche, sur le sonomètre et son support, sont inévitables. Dans cet article, on montre comment l'emploi de sons hululés supprime les réflexions dans le champ éloigné et comment les réflexions sur le sonomètre affectent les caractéristiques directionnelles et la réponse en fréquence.

ZUSAMMENFASSUNG

Bei der Messung der Richtcharakteristik und des Frequenzganges von Schallpegelmessern, sind Fernfeldreflexionen von den Wänden des Schalltoten Raumes sowie Nahfeldreflexionen vom Gehäuse des Schallpegelmessers einschließlich der Befestigungsvorrichtung, unvermeidlich. In diesem Artikel wird gezeigt, wie durch die Verwendung von Wobbeltönen anstelle von reinen Tönen die Fernfeldreflexionen eliminiert werden können und wie die Reflexionen vom Gehäuse des Schallpegelmessers die Richtcharakteristik und den Frequenzgang beeinflussen.

Introduction

Measurements of frequency response and directional characteristics of sound level meters should in principle be carried out in an ideal free sound field, i. e. a field in which plane progressive waves exist, whereby the sound level measured in arbitrary positions would be identical. Since such an environment (although well defined) is almost im-

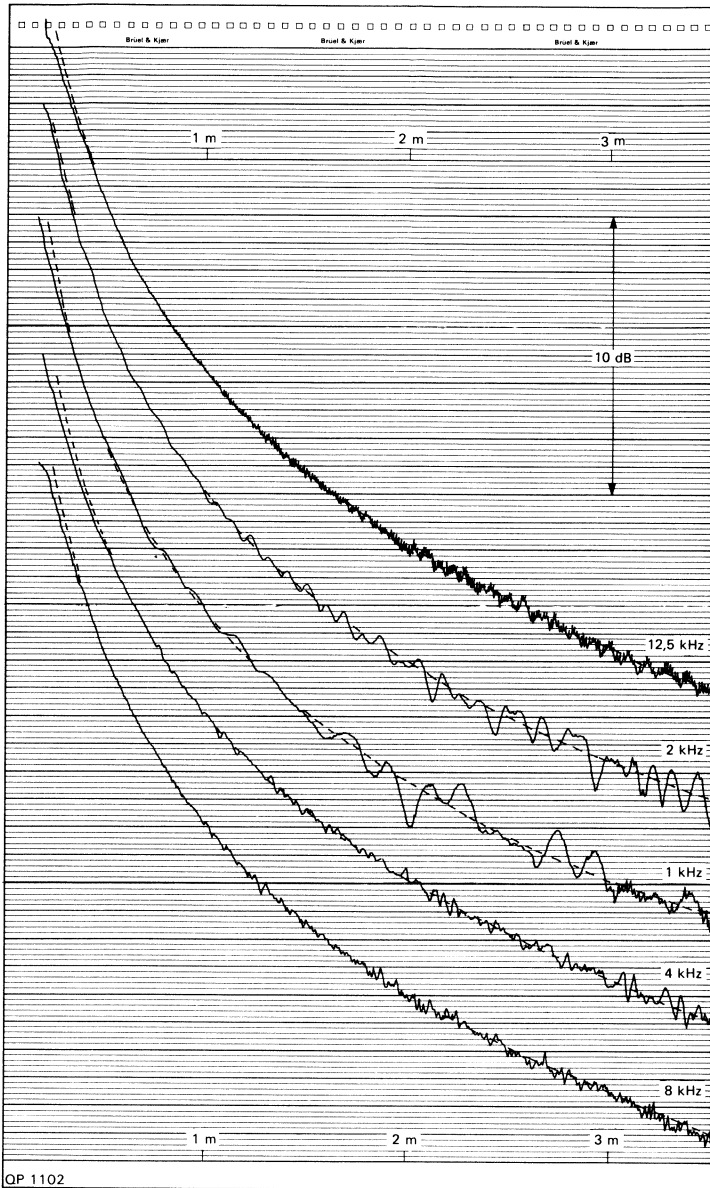

Fig. 1. Sound pressure level as a function of distance. Theoretical curves are shown by dotted lines (for the higher frequencies corrected for air absorption)

possible to achieve in practice, appreciable errors can occur when measurements are carried out on sound level meters, due to the inevitable sound reflections. If these reflections are not eliminated, the errors in some cases can be of the same order of magnitude as the tolerances concerned.

The quality of anechoic chambers where frequency response and directional characteristic measurements are carried out, is obviously of great importance for reliability of the results. An assessment of the errors to be expected at a certain distance from the sound source can be achieved by examination of the deviations from the distance law, Fig.1. It can be seen, that although the curves in general adhere to the distance law, deviations of an order of magnitude of 1 dB often occur for small variations of the distance. Similar deviations may occur for small frequency variations (10 to 20 Hz). These deviations, which are due to interferences in the room, may result in significant measurement errors as will be shown later.

Since the cost of very large anechoic chambers, necessary for ideal measurement conditions, cannot always be justified, a measurement method is outlined in this article whereby the far field reflections from the walls of the anechoic chamber are practically eliminated. However, the near field reflections from the sound level meter body will affect the directional and frequency response characteristics dependent on the phase of the reflected waves from different parts of the sound level meter body.

Measurement Procedure

(a) Sound Source

The sound source selected must be such that it does not give rise to interference phenomena over the distance where the measurements are to be carried out. A small sound source will meet this requirement, as it will act as a point source even from a relatively short distance. A condenser microphone used as a transmitter is thus one good possibility.

(b) Distance between the Sound Source and Receiver

The choice of the distance between the sound source and the receiver (a sound level meter or a microphone) is usually a compromise, depending upon the size of the anechoic room, the mechanical dimensions of the sound level meter and the sound radiation level available from the sound source. Since the sound pressure level is inversely proportional to the distance, the sound level meter must be far enough so that the

sound pressure level is approximately the same at the microphone and at the sound level meter body. On the other hand, if the distance chosen is too large, the ratio between the levels of the direct sound from the sound source and the reflected sound from the walls would be unfavourable. It may also be difficult to obtain a sufficiently high sound pressure level.

(c) Measurement Set-up

As seen from the foregoing, a given measurement set-up will be a compromise between inevitable sources of error. By examining the characteristics of microphones alone (without the sound level meter body in the sound field), it is possible to establish more satisfactory compromises of measurement techniques and thereby better accuracy. Since the mechanical dimensions of the microphones are small, and if a second microphone is used as a sound source, the distance between the sound source and the microphone can be kept small. The direct sound will therefore in this case often be high enough, compared with the sound reflected from the measuring environment, so that the influence of the reflected sound can be neglected. Furthermore, the mechanical structure of the measurement set-up can be made so delicate that its influ-

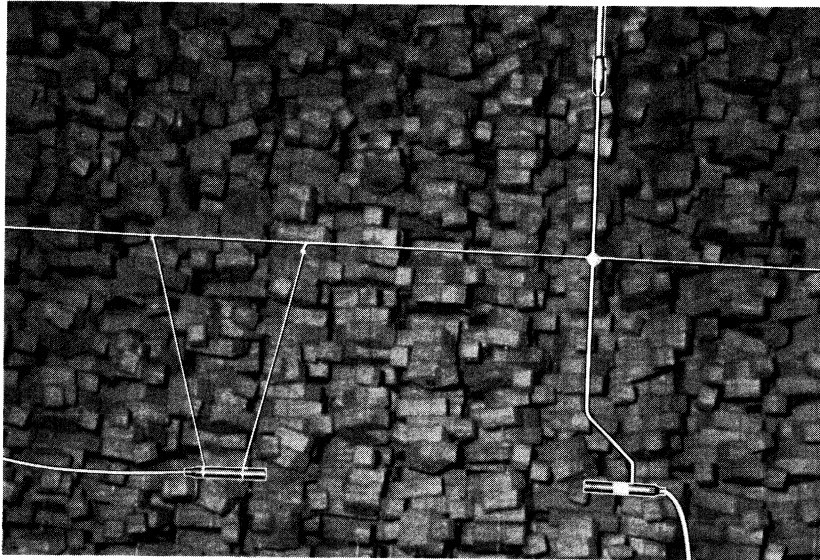

Fig.2. Measurement set-up for microphone characteristics

ence will be insignificant. Thus the microphone characteristics will often be better defined and can therefore be used as a comparison when evaluating the results of investigations made on actual set-ups used for sound level meter measurements. The degree of reproducibility of known microphone characteristics in a measurement set-up (where the sound source, the distance between the sound source and the sound level meter, the mechanical supporting structure and its positioning in the anechoic chamber etc. are all suitable for sound level meter measurements) will be a good indication of the uncertainty which can be expected, and to what extent improvements are necessary to obtain a given degree of accuracy.

An example of a measurement set-up for microphones is shown in Fig.2. The sound source used is a 1/2" Condenser Microphone Type 4165. The measuring object (also a Type 4165 Microphone) can be rotated by a turntable placed on the roof of the anechoic chamber.

For the measurement of sound level meter characteristics (free-field frequency response, directional characteristics), the set-up shown in Figs.3.1 to 3.4 was used. To minimize the influence of the mechanical supporting system on the sound field, it was made as a rather delicate "lattice-work" fixed to a Turntable Type 3921. The turntable itself was not fastened to the anechoic room, as it was desirable to change its position in order to investigate the influence of repositioning. To keep the set-up in balance, a counterweight (see Fig.3.4) was attached. As sound source a 1" Condenser Microphone Type 4144 was chosen. The distance between the sound source and the sound level meter was chosen to be 2 meters for the directional characteristics. For the present sound level meter type and the given anechoic chamber (5,7 × 5,1 × 5,3 m), this was considered to be a reasonable compromise between signal-to-noise ratio, distance to the walls and the requirement of sufficient distance to approximate a plane, progressive sound field.

A condenser microphone used as a sound source, when fed with a constant voltage, will give rise to a sound pressure level increasing by 12 dB/octave (valid for flat, free-field frequency response in the direction used). It is therefore difficult to obtain a sufficiently high sound pressure level at lower frequencies. With the present system it was possible to carry out directivity measurements down to 1 kHz, since the sound radiated could be appreciably increased (20 to 30 dB) by means of a $\lambda/4$ -tube mounted on the front of the sound source. For measurement of the frequency response, this was naturally impossible, so the distance here had to be reduced to 1 meter and the lower frequency li-

mit to 2 kHz. Nevertheless, there was reasonably good correlation between the measurement results obtained in both cases.

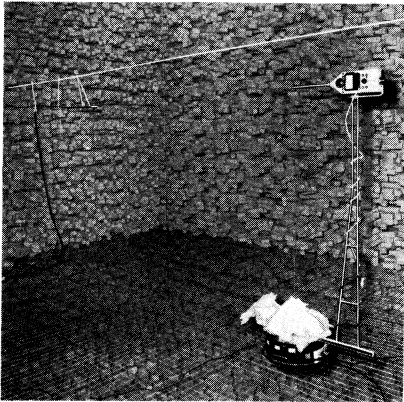

Fig. 3.1.

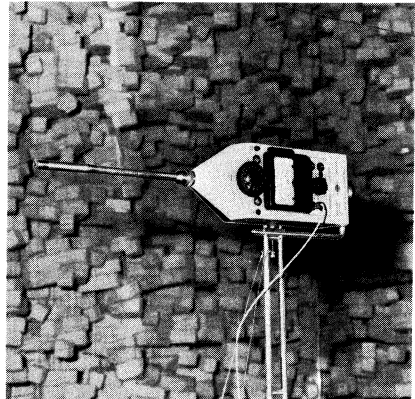

Fig. 3.2.

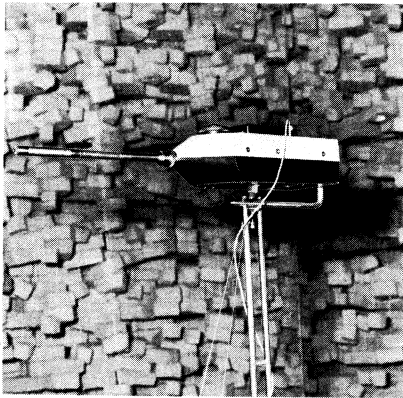

Fig. 3.3.

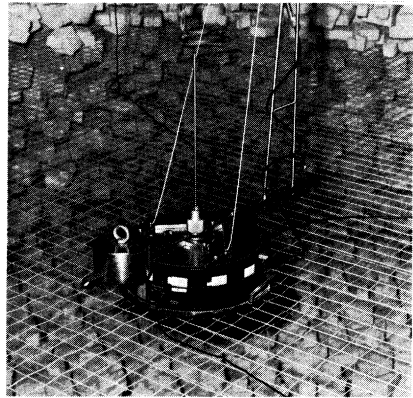

Fig. 3.4.

Measurement set-up for sound level meter

To examine the characteristics of the measurement set-up, measurements of the directional sensitivity of a Microphone Type 4165 with well defined characteristics were carried out. The set-up is shown in Fig.4. From the measurement results (Fig.5, dotted curves), it can be seen that for small frequency deviations (± 20 Hz, ± 50 Hz), the characteristics measured deviate considerably. These deviations, which are

not characteristic of the microphone, are consequently due to incorrect measurement conditions.

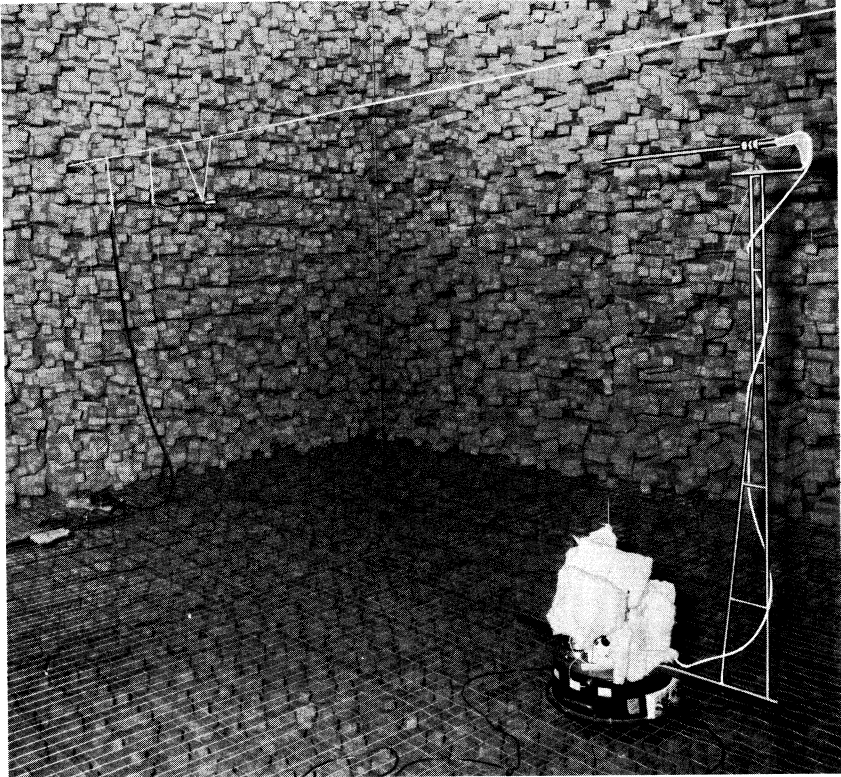

Fig.4. Examination of the mechanical set-up used for sound level meter measurements

Sources of Error

The deviation in the measurement results can be attributed to the following main sources of error:

- 1) The primary cause of measurement errors is in most cases, due to interference phenomena, arising either from the sound source or from reflections from the walls of the anechoic chamber. Errors of this nature may result in relatively large variations of sound pressure level for small changes in distance from the sound source.

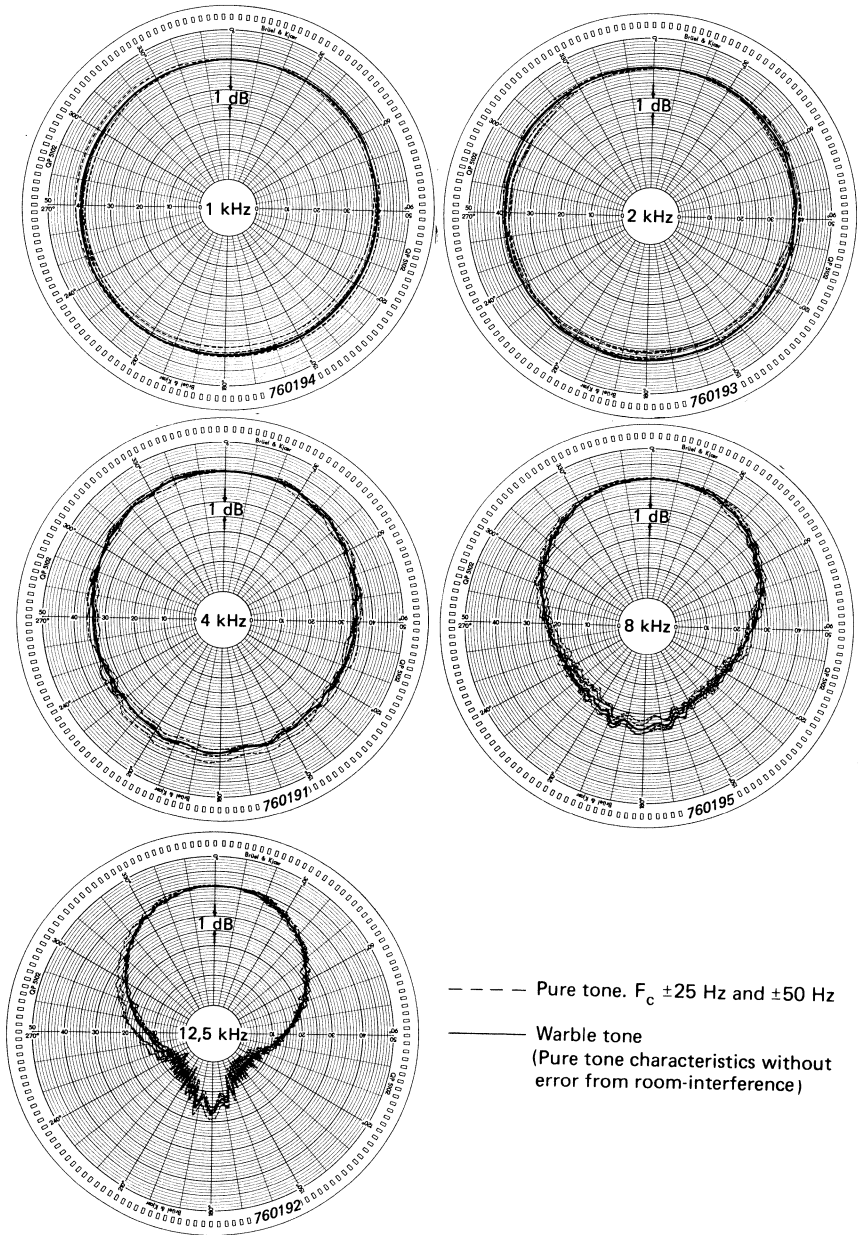

Fig.5. Directional characteristics of Microphone Type 4165 using pure tones and warble tones

- 2) When examining the directional characteristics, the position of the microphone or sound level meter may appear to change if it is not rotated around its acoustical centre. This error is extremely difficult to eliminate, as the acoustical centre is not a fixed point defined by the mechanical dimensions of the microphone, but a point whose position is dependent on the angle of incidence of the sound, the distance from the sound source and the frequency. It should, however, be noted that the change in the position of the acoustical centre will affect the results only when there are interference phenomena, and would have no influence in an ideal free sound field.
- 3) On account of reflections the sound may change direction of incidence. This error will generally be small except for measurements on microphones with high directionally dependent sensitivity.
- 4) Large sound sources, e. g. a loudspeaker, may give rise to errors due to reciprocal influence if the distance between the source and receiver is relatively small.
- 5) Reflections and diffractions from the supporting structure for the sound level meter may also give rise to significant errors. However, there is a practical limit for improvements in this area if the requirement for a mechanically stable structure is to be fulfilled.

Improved Measurement Method

Elimination of far-field Reflections

It can be seen from the sources of error mentioned above, that the accuracy of measurement results can be increased significantly if the reflections are eliminated. The influence from reflecting objects can be reduced by increasing their distance from the microphone, however, the improvements that can be achieved in this manner are limited.

Another way of diminishing the reflected waves is by using warble tones (frequency modulated tone) for calibration, instead of pure tones. If the frequency deviation (and thereby the bandwidth) is sufficiently small, only relatively small phase changes occur for the frequency components of the reflected signal due to objects close to the microphone. Hence the reflected signals from the body of the sound level meter will behave almost in the same manner as for a pure tone. On the other hand, since the walls of the anechoic chamber are relatively far from the microphone, the frequency components of the reflected signals, in this case, change in relative phase with each other (due to the modula-

tion of the centre frequency) and thereby gradually compensate each other. If a constant, absolute bandwidth is used, the compensation effect will be independent of the frequency. However, a lower frequency limit for the method will be reached when the necessary frequency modulation (dependent on the distance to the undesired reflecting surfaces) is appreciable compared with the centre frequency. In practice, this limit would be around 1 kHz.

In the appendix a measurement set-up is described for determining the compensation effect obtained by the use of warble tones, as a function

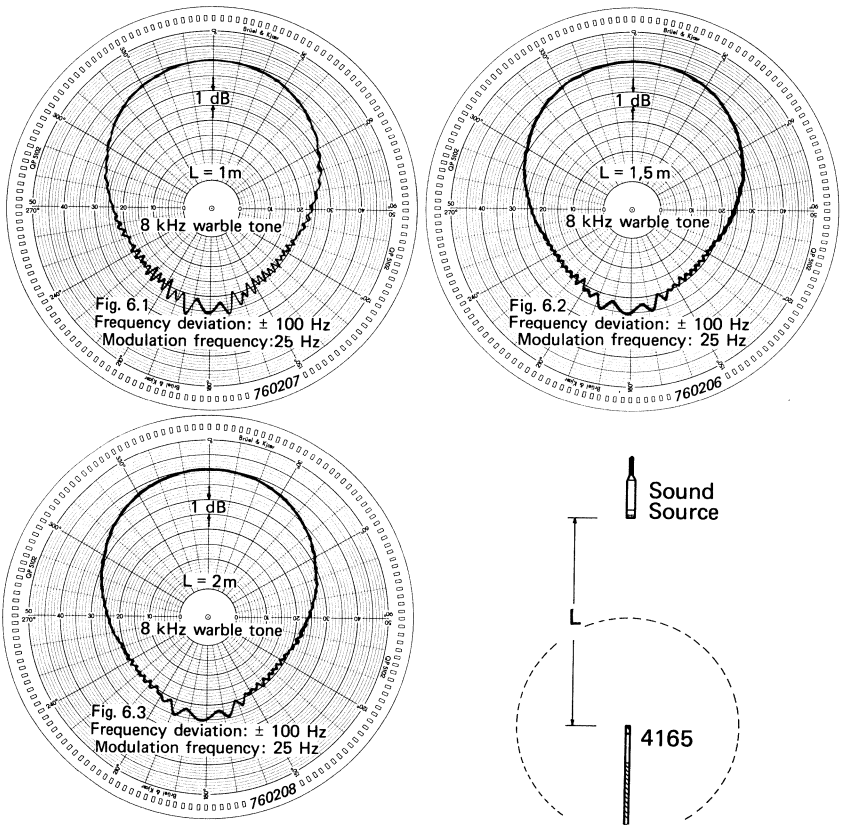

Fig. 6. Directional characteristics of Microphone at different distances using warble tones

of distance. It is shown, that for the bandwidth used, the reflections from a surface less than 0,5 m away from the microphone (e.g. the body of the sound level meter) will be similar for both pure tones and warble tones, whereas the frequency components of the reflected signal from a surface at a distance of 2 m and greater will compensate each other for a warble tone. If frequency response and directional characteristic measurements are carried out at a distance of 2 m from the walls of the anechoic room, where the reflections are already at a low level, the use of warble tones will simulate measurements in a room with an extremely low reflection level.

Using the measurement set-up for sound level meter characteristics (Fig.4) the directional characteristics of a Microphone Type 4165 were carried out with the use of warble tones. From the results obtained and shown in Fig.6, it can be seen that the reproducibility is quite good for measurements carried out at different distances from the sound source, and that small frequency deviations have no influence. Comparison should be made with the results obtained by pure tones shown in Fig.5 where the directional characteristics for the frequency range 1 kHz to 20 kHz using warble tones are also shown (fully drawn lines).

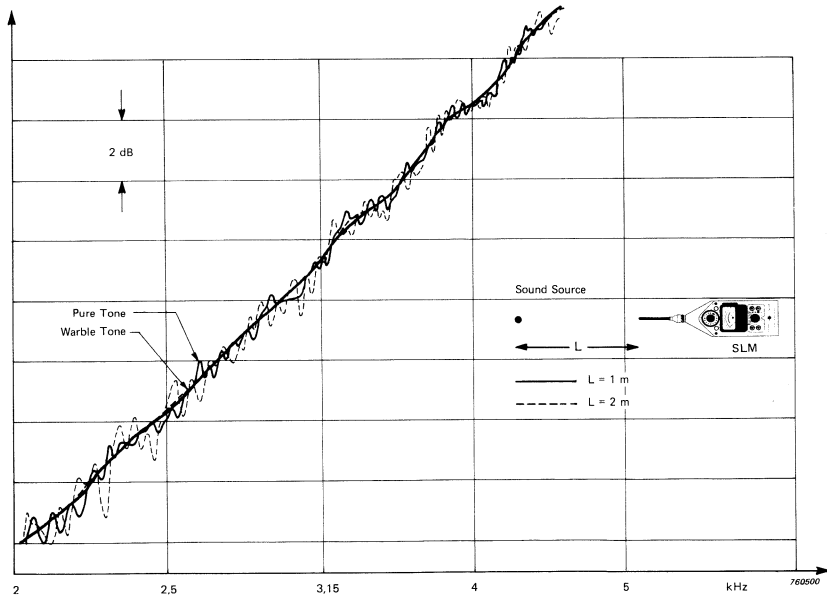

Fig. 7. Frequency response of sound level meter using pure tones and warble tones at 1 and 2 m distance

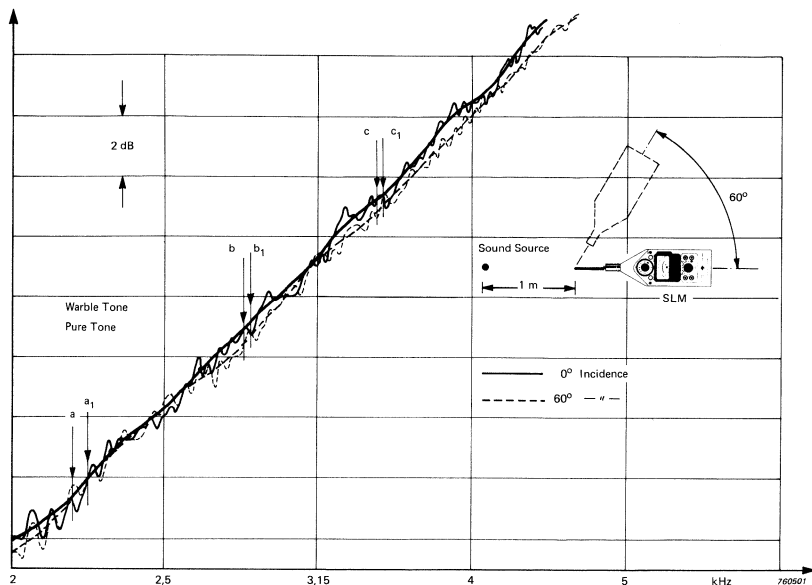

Fig.8. Frequency response of sound level meter using pure tones and warble tones at 0° and 60° incidence

The advantages of using warble tones instead of pure tones can also be seen for frequency response measurements, see Fig.7. The reproducibility of measurements at different distances using warble tones is considerably higher than that for pure tones. Measurements of frequency response Fig.8, also reveal that for pure tones the room errors are not reproduced for the different angles of incidence shown, which are most likely due to the change in position of the acoustical centre, (compare $a-a_1$, $b-b_1$, $c-c_1$).

Near field Reflections from Sound Level Meter Body

So far we have considered and practically eliminated the far field reflections from the walls of the anechoic chamber by the use of warble tones. The near field reflections from the sound level meter body will now be considered, since the directional sensitivity and frequency characteristics depend partly on the microphone characteristics and partly on diffractions around the sound level meter body.

(a) Directional Sensitivity

If sound reflection from the sound level meter body is considered to come from only one reflecting surface with a reflection coefficient k ,

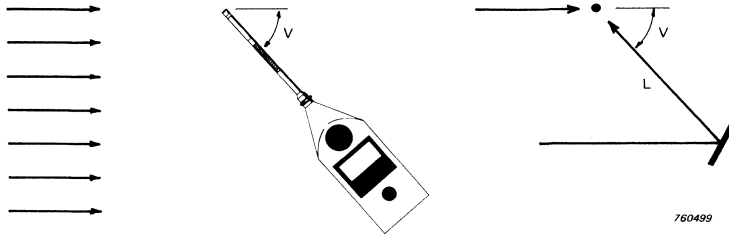

Fig.9. Sketch illustrating the direct and reflected sound wave and the angle between them

Fig.9, it can be seen that for a plane progressive sound wave the distance travelled by the reflected sound would be $l(1 + \cos v)$ longer than the distance travelled by the direct sound, where l is the distance between the reflecting surface and the microphone and v is the angle of incidence.

The phase angle between the direct and reflected sound would then be

$$\alpha = \frac{l(1 + \cos v)}{\lambda} \times 360 \text{ degrees}$$

where λ is the wavelength. If the direct sound pressure has an amplitude A , the resulting sound pressure at the microphone would be

$$A_1 = A \left[1 + k \cos\left(\frac{l(1 + \cos v) 360}{\lambda}\right) G(\lambda, v) \right]$$

where $G(\lambda, v)$ is the directional characteristic of the microphone. It can be seen that if the reflected sound is in phase with the direct sound at an angle of 0° incidence, thus giving an increase in sensitivity at a particular frequency, there will be a corresponding decrease in sensitivity at another angle dependent on l and λ . Similarly, a decrease at 0° incidence will correspond to an increase at another angle of incidence. Fig.10.1 shows an example calculated for $l = 31,175 \text{ cm}$, $k = 0,03$ and $\lambda = 4,3 \text{ cm}$, $4,38 \text{ cm}$ and $4,45 \text{ cm}$ ($f = 8 \text{ kHz}$, $7,85 \text{ kHz}$ and $7,72 \text{ kHz}$). However, if the same directional sensitivity characteristics are drawn with the 0° incidence sensitivities as the reference level (as suggested in IEC 179), they will appear as shown in Fig.10.2. The characteristics in this case seem to deviate much more than they do in actual fact. To take the above-mentioned near field reflection dependence into account, without changing the already specified tolerances for sound level meters, a new text, or interpretation of the tolerance table for the maximum variation in sensitivity at angles of $\pm 30^\circ$ from the reference direc-

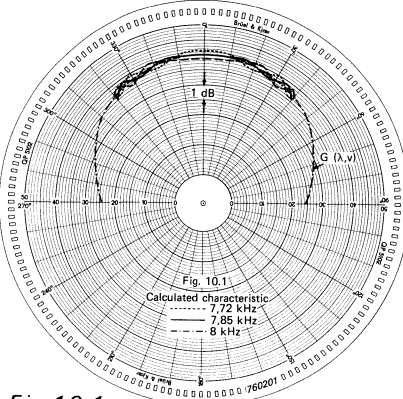

Fig. 10.1.

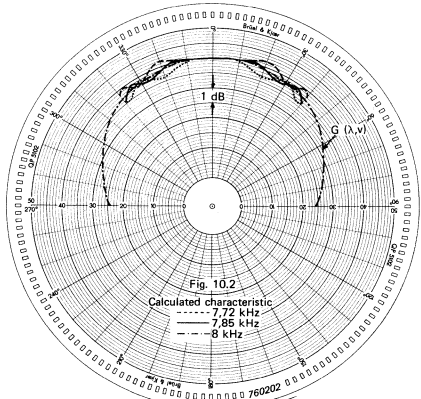

Fig. 10.2.

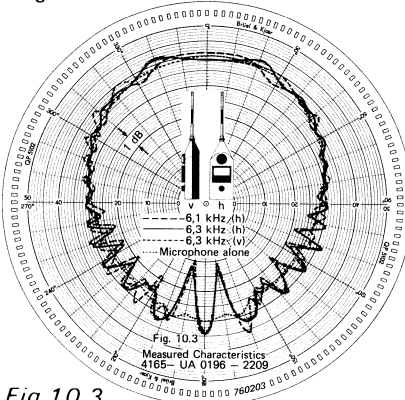

Fig. 10.3.

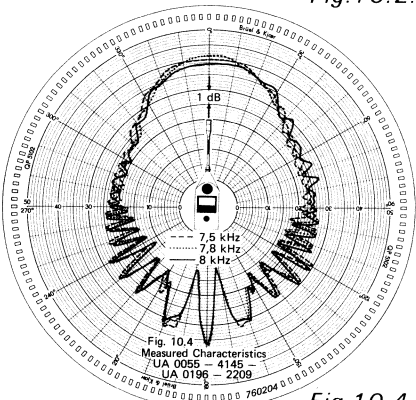

Fig. 10.4.

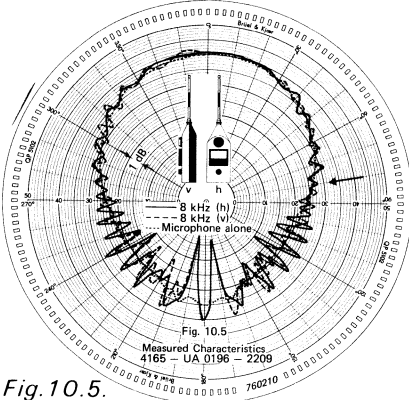

Fig. 10.5.

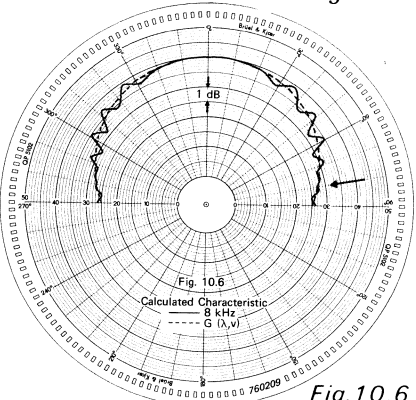

Fig. 10.6.

Calculated and measured directional characteristics for the sound level meter

tion could be suggested as follows: "Max. peak-to-peak change in sensitivity within an angle of $\pm 30^\circ$ from the reference direction specified". In the table, $\pm 0,5$ dB should be changed to 1 dB, $+ 0,5 - 2$ dB to 2,5 dB and so on. Figs.10.3 and 10.4 show examples of measurement results where this interpretation is taken into account. The "changes" for the 0° incidence levels were made in accordance with the actual sound pressure levels measured for the particular frequencies at 0° incidence.

The calculated example for only one reflecting surface will hardly be valid for practical cases, but will approximate the case for small changes of frequency and small changes of the angle of incidence. In

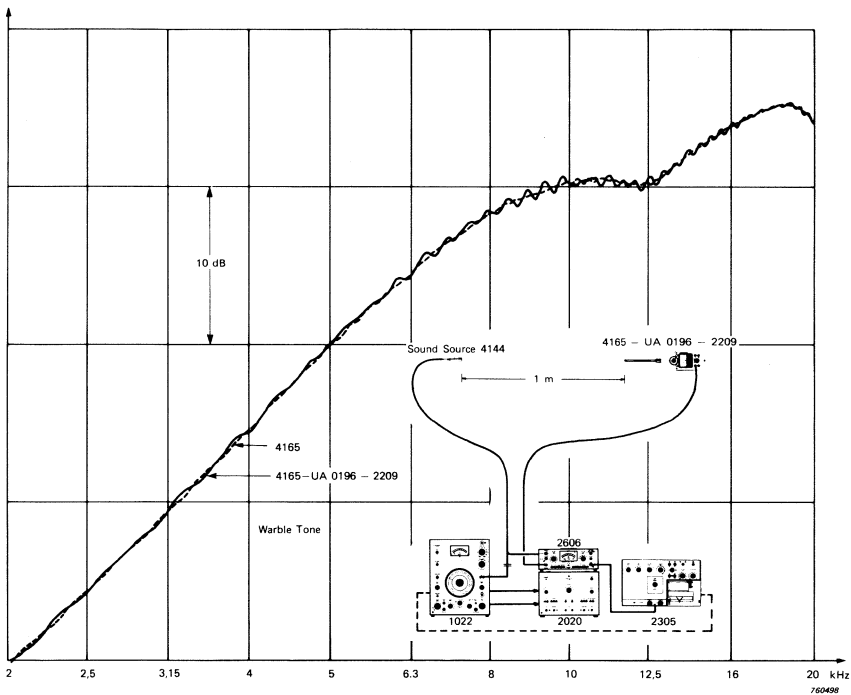

Fig.11. Comparison of microphone and sound level meter frequency characteristics using warble tone frequency sweep

practical cases, the reflections will occur from different zones of the sound level meter body depending on frequency and angle of incidence of the sound. This may result in suppression of the "waves" on the di-

rectional characteristics for certain angles of incidence, dependent on the frequency, and gained effect for others, as the signals reflected from different zones are in inverse phase or in phase (see Fig.10.5, 75° to 90°). A calculated example where two reflecting zones are assumed, is shown in Fig.10.6.

(b) Frequency Response

The effects of the near field reflections from the sound level meter body can also be seen on the frequency response characteristics shown in Fig.11 obtained using the set-up illustrated in Fig.3.3. For comparison the characteristics of the microphone alone (without the sound level meter) are also shown (dotted curve).



range 5 — 10 kHz and for 0° and 30° incidence. *It can also be concluded that small changes in the distance between the microphone and the sound level meter body will only alter the phase of the "waves" seen on the frequency characteristics, whereas the general characteristics will remain unchanged.*

(c) Random Incidence Frequency Response

IEC 179 suggests that the sensitivity for a diffuse sound field may be calculated from the free-field response for 0°, 30°, 60°, 90°, 120°, 150° and 180° angles of incidence. This will generally be valid for microphones, but analysis of the directional characteristics for sound level meters, especially for frequencies in the range 5 to 10 kHz, reveal that a calculation on this basis will be very unreliable. A calculation based on similar characteristics measured with 1/3 octave random noise, instead of pure tones, will result in less uncertainty, since the band noise characteristics will be mean values for the frequency bands. Also, from a practical point of view it would be more convenient, as the results would be based on a finite number of measurements. Directional characteristics obtained with the use of 1/3 octave frequency bands are shown in Fig.13.

Conclusion

From the measurements carried out, it can be seen that a careful examination of the acoustical characteristics of a sound level meter is necessary to describe the apparatus as a whole. Also, examination at only some key frequencies will not be reliable and will not in general be representative of the apparatus type. On the other hand, changes in characteristics (for a type of apparatus) which cannot be defined by a rather simple measurement technique, are unlikely to occur in practical cases.

Furthermore, it must be pointed out that small deviations, which can be stated only under extreme conditions as defined by pure tones and ideal free sound field, will hardly be noticeable under practical conditions and therefore the measuring accuracy will generally be better than that immediately indicated by the tolerance levels.

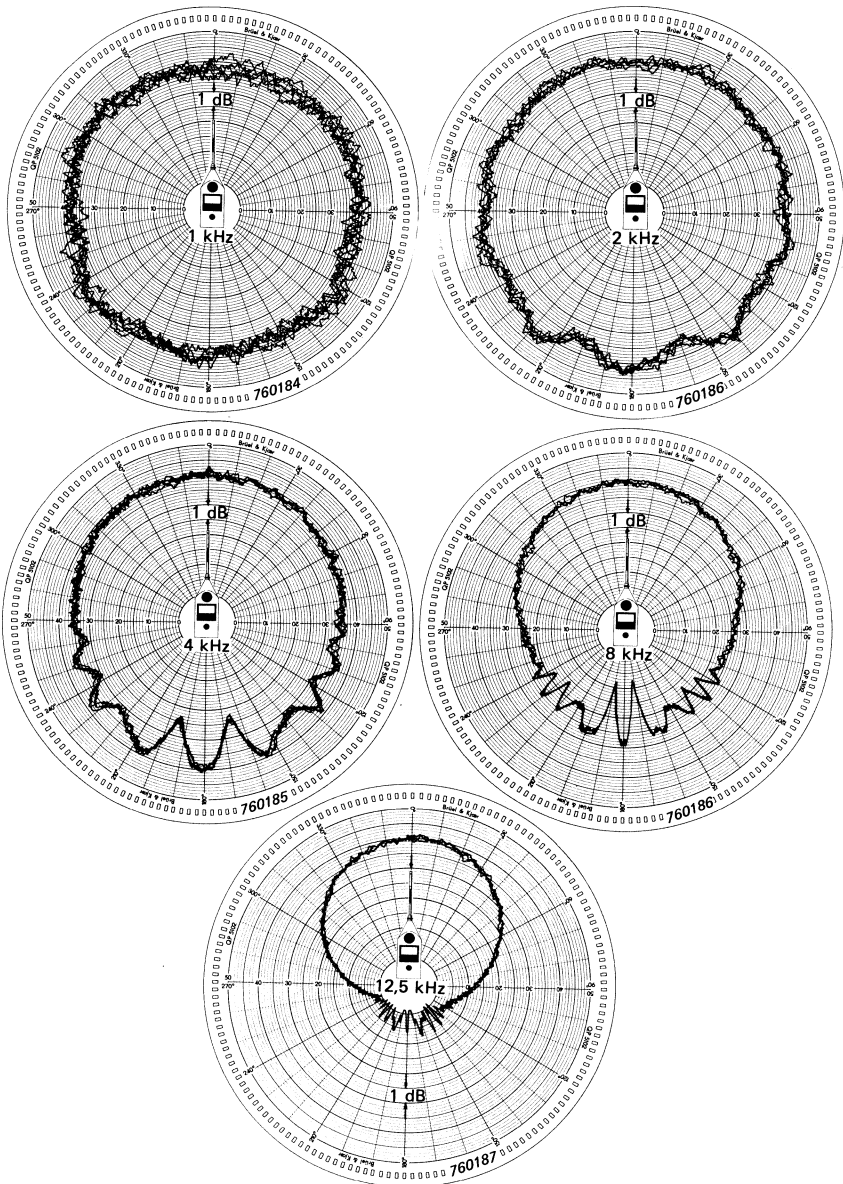

Fig.13. Directional characteristics for sound level meter using 1/3 octave random noise band

APPENDIX

Compensation of Reflected Waves using Warble Tones

The normal method of reducing the influence from a reflecting object by increasing its distance from a microphone has practical limits. How-

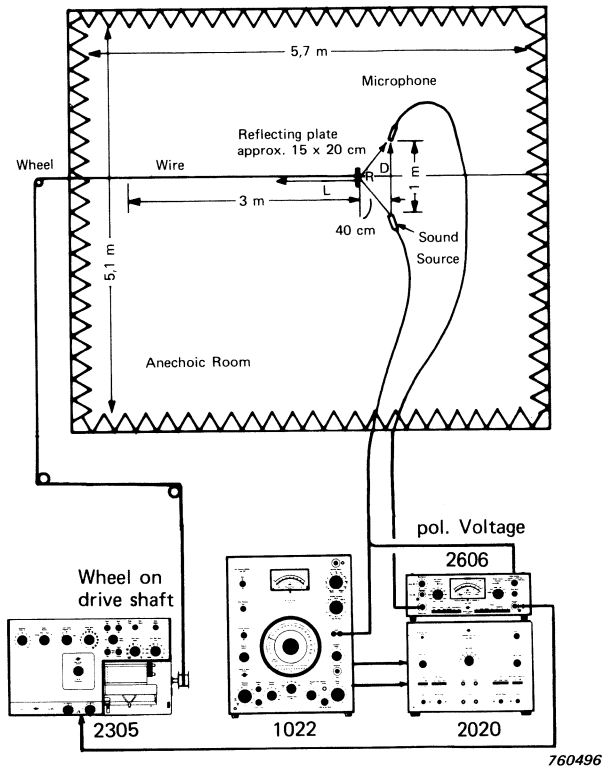

Fig.A1. Set-up to demonstrate the advantages of using warble tone technique

ever, another method of diminishing the reflected waves is by the use of warble tones (instead of pure tones) in which case the frequency components of the reflected waves (for example from the walls of the anechoic chamber) change in relative phase to each other and thereby compensate each other. A set-up to demonstrate this effect is shown in Fig.A1.

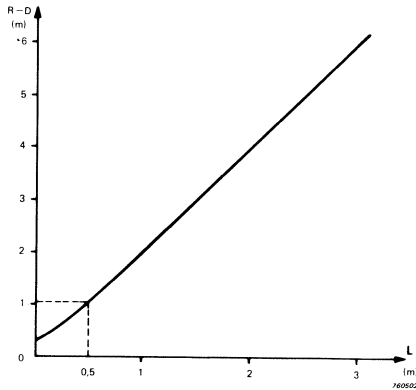

Fig.A2. Difference between the distance travelled by the reflected and direct sound as a function of the position of the reflecting plate

A reflecting plate is moved along a wire by means of a mechanical drive system connected to a level recorder. The length of the reflected sound path R can thus be varied, while the length of the direct sound path D remains constant. Fig.A2 shows a plot of $R-D$ (the difference between the distance travelled by the reflected signal and the direct signal) against L the distance moved by the reflecting plate. The resulting sound pressure level at frequencies 1, 2, 4, 8 and 16 kHz for both pure tones and warble tones (frequency deviation ± 100 Hz; modulation frequency 25 Hz) are recorded as the reflecting plate is moved along. From Fig.A3, which shows the sound pressure level recorded as a function of L (the distance moved by the plate), it can be seen that for $L \leq 0,5$ m there is no significant difference between the results obtained for pure tones and warble tones. For $L > 0,5$ m the influence of the reflected warble tones can be seen to die out much more rapidly.

This means that reflections from the body of a sound level meter with a total length up to 0,5 m will be similar for both pure tones and warble tones, whereas the reflections from a surface at a distance of 2 m will be eliminated. (From Fig.A2 it can be seen that for $L = 0,5$ m the dis-

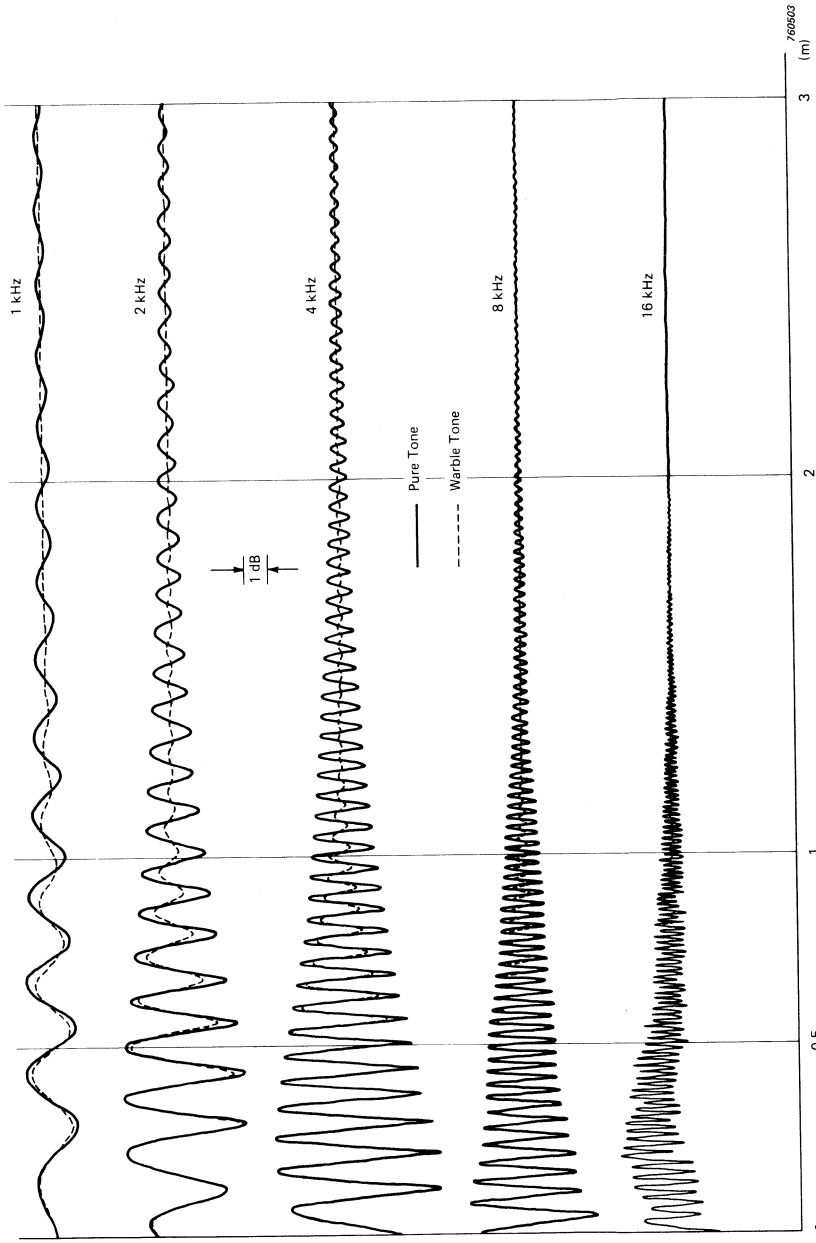

Fig.A3. Variation of the sound pressure level as a function of L (the distance moved by the reflecting plate)

tance travelled by the reflected signal is 1 m longer than that for the direct signal.) If measurements are carried out at a distance of approximately 2 m from the walls of an anechoic chamber, where the reflections are already at a low level, the use of warble tones will simulate measurements in a room with an extremely low reflection level. The larger the anechoic chamber and the lower the reflection coefficient of the damping material of the walls, the smaller will be the necessary frequency deviation for the warble tone, to remove the rest of the room interferences, and the higher the general accuracy.

High Frequency Testing of Gramophone Cartridges Using an Accelerometer

by

O. B. Sørensen

ABSTRACT

It is shown how a piezoelectric accelerometer can be used as an exciter to obtain high frequency response of gramophone cartridges. By this method impulse testing is possible as well as absolute calibration of the cartridges. Advantages of this method over conventional methods using test records are also shown.

SOMMAIRE

On montre comment un accéléromètre piézoélectrique peut être utilisé comme excitateur pour obtenir la réponse haute-fréquence des phonocapteurs. Cette méthode permet les essais en impulsions aussi bien que l'étalonnage absolu des phonocapteurs. Les avantages de cette méthode, par rapport aux méthodes conventionnelles utilisant des disques d'essais, sont aussi mis en évidence.

ZUSAMMENFASSUNG

Es wird gezeigt, wie ein piezoelektrischer Beschleunigungsaufnehmer als Erreger verwendet werden kann, um hohen Übertragungsfrequenzgang der Tonabnehmerköpfe an Plattenspielern zu erhalten. Diese Methode ermöglicht Prüfung der Impulse sowie absolute Kalibrierung der Tonabnehmerköpfe. Die Vorteile dieser Methode gegenüber dem konventionellen Verfahren mit Hilfe von Meßschallplatten werden ebenfalls gezeigt.

Introduction

A piezoelectric accelerometer, as the name itself suggests, is a vibration transducer that measures acceleration. However, since the piezoelectric effect is reversible, an accelerometer can be used as a vibrator, when voltage is applied across its terminals. The use of an accelerometer as a vibrator can render significant advantages for excitation at high frequencies, since a subminiature accelerometer, such as the Brüel & Kjær Type 8307 has a very flat frequency response up to 45 kHz. The accelerometer, when placed with its axis in the horizontal plane on foam rubber, can thus be used for testing gramophone cartridges in the

four modes L, R, L + R and L — R. Also the errors involved in conventional methods of pick-up testing with the use of test records, such as the geometrical and deformation faults in the groove wall, can be avoided.

Theory

From the reciprocity theorem it is well known that for a piezoelectric transducer the following relations hold:

$$v = S_{acc} j\omega \dot{x} + \frac{1}{j\omega C} i \quad (1)$$

$$F = Mj\omega \dot{x} + j\omega S_{acc} i \quad (2)$$

- where
- S_{acc} = accelerometer voltage sensitivity, Volts s^2/m
 - C = accelerometer capacity, Farads
 - F = force on accelerometer, Newtons
 - \dot{x} = accelerometer velocity, m/s
 - v = voltage across accelerometer, volts
 - i = driving current, amps
 - M = accelerometer mass, kg
 - ω = angular frequency, rad/s

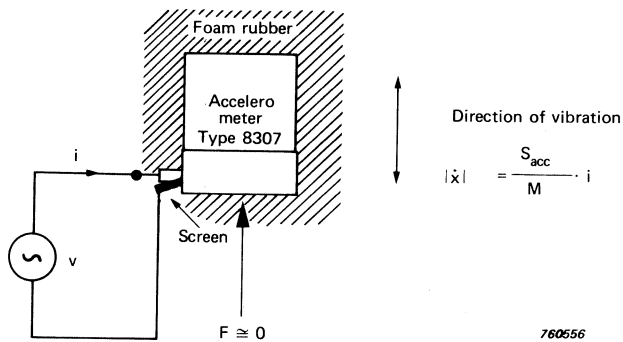

Fig. 1. Accelerometer used as an exciter

Fig. 1 shows an accelerometer Type 8307 placed on foam rubber with the integral cable cut off. When the cartridge is placed laterally on the accelerometer, the force acting in the axial direction of the accelerometer can be considered to be negligible, whereby equation (2) can be modified to

$$|\dot{x}| = \frac{S_{acc}}{M} i \quad (3)$$

Thus by measuring the voltage supplied to the accelerometer and knowing its capacity, voltage sensitivity and mass, the velocity of the accelerometer can be determined.

However, if the velocity level is to be known very precisely, e. g. for absolute calibration, then the current (instead of voltage) fed to the accelerometer should be measured. This is because the voltage across the accelerometer would not be that fed from the generator, but a value modified by the amount $(S_{acc} j\omega\dot{x})$, see equation (1) and calibration section.

Measurement Procedure

Fig.2 shows a measurement set-up for frequency response of gramophone cartridges. For fixing the pick-up stylus on the accelerometer (placed on foam rubber) a 0,1 mm diameter hole was drilled in the accelerometer side with a drill bit of point angle 90° to correspond to the angle of groove walls found on test records. However, no differences were observed between the frequency response curves obtained with

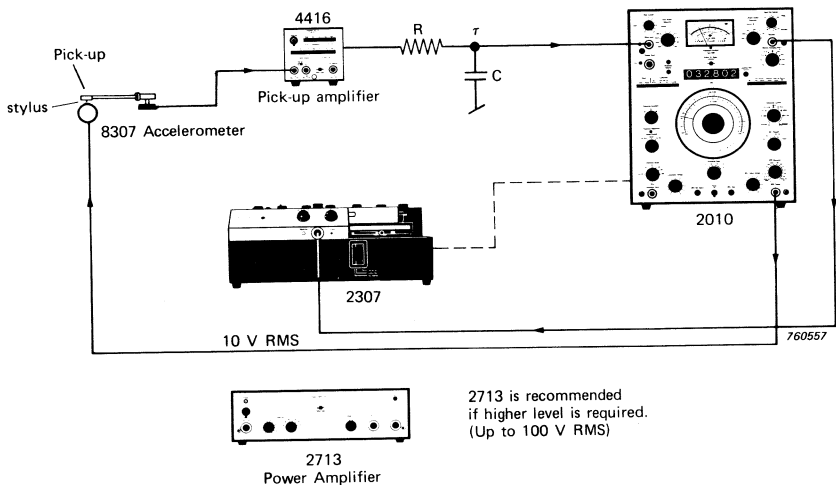

Fig.2. Measurement arrangement for high frequency response of gramophone cartridges

the stylus placed in the hole and when placed directly on the accelerometer for a driving voltage of 10 V RMS from the generator. This is because of the very low displacement levels generated on the accelerometer. When a constant voltage is applied to the accelerometer by the Heterodyne Analyzer Type 2010, the current increases at 6 dB/oct. as the frequency is scanned on account of the very low output impedance (a few ohms) of the generator. Thus the velocity of the accelerometer also increases at 6 dB/oct. as seen from equation (3), i. e. the displacement of the accelerometer is constant.

The signal from the cartridge is led to a Response Test Unit Type 4416 which has a 50 dB lin. gain. Since the velocity of the accelerometer increases at 6 dB/oct. and the cartridge is a velocity sensitive transducer, the output from the Response Test Unit would also increase by 6 dB/oct. Therefore an integration network is placed after the Response Test Unit to give a constant output as the frequency is scanned. The RC time constant of the integration network was chosen to be 75 μ s to obtain as low frequencies as possible. If the background vibration level is low, the time constants in 4416 could be used. Since the max. available voltage from the generator is approx. 10 V RMS, the displacement of the accelerometer would be relatively low. The output from the integration network is therefore filtered by feeding it to the analyzer section of the 2010 with a bandwidth of 3.16 Hz or 10 Hz to give a signal/noise ratio of 40 dB or more. The output from the analyzer is fed to a Level Recorder Type 2307 which is synchronized with the analyzer by a mechanical drive.

If a higher displacement level on the accelerometer is desired, a Power Amplifier Type 2713 with an output of 100 V RMS could be used between the generator and the accelerometer. This could be necessary for example in case of impulse testing as shown in the Appendix.

Calibration

As shown in the Theory section, the velocity generated on the accelerometer is given by the expression

$$|\dot{x}| = \frac{S_{acc}}{M} \quad i$$

Since the accelerometer Type 8307 has a voltage sensitivity of approximately 2×10^{-4} Vs²/m, a mass of 4×10^{-4} kg and a capacity of 250 pF the velocity generated at 10 kHz for a supply voltage of 10 V RMS would be:

$$\dot{x} = \frac{2 \cdot 10^{-4}}{4 \cdot 10^{-4}} 2\pi \cdot 10^4 \cdot 250 \cdot 10^{-12} \cdot 10 \text{ m/s}$$

assuming $i = 2 \pi f C v$ where C is accelerometer capacity and v is supply voltage.

i. e. velocity $\dot{x} \approx 78,5 \cdot 10^{-6} \text{ m/s}$

displacement $x = \frac{\dot{x}}{\omega} \approx 12,5 \cdot 10^{-10} \text{ m}$

and acceleration $\ddot{x} = \omega \dot{x} \approx 4,9 \text{ m/s}^2$

However, for absolute calibration of the pick-up stylus the current fed to the accelerometer must be determined accurately to evaluate the velocity of the accelerometer. The current fed to the accelerometer would not be given exactly by the expression assumed above, since it can be seen from equation (1) that the voltage applied across the accelerometer would be the voltage supplied by the generator modified by a quantity $S_{acc} j\omega \dot{x}$.

By connecting a precision resistor in series with the accelerometer and measuring the voltage across it, the current fed to the accelerometer can be determined.

For absolute calibration of the pick-up stylus a $1 \text{ k}\Omega$ resistance was connected in series with the accelerometer and a voltage drop of 14 mV was measured across it at 1 kHz for a voltage supply of 10 V RMS from the generator. The exact voltage sensitivity of the accelerometer was $2,24 \times 10^{-4} \text{ Vs}^2/\text{m}$ and the velocity of the accelerometer was then calculated from

$$|\dot{x}| = \frac{S_{acc}}{M} i = \frac{2,24 \cdot 10^{-4}}{4 \cdot 10^{-4}} \cdot \frac{14 \cdot 10^{-3}}{10^3}$$

$$\therefore |\dot{x}| = 7,84 \cdot 10^{-6} \text{ m/s}$$

The voltage from the pick-up was measured to be 590 nV which gives an absolute sensitivity of the pick-up to be

$$S_{pu} = \frac{590 \cdot 10^{-9}}{7,84 \cdot 10^{-6}} = 75 \cdot 10^{-3} \frac{Vs}{m}$$

or

$$S_{pu} = 0,75 \frac{mV \cdot s}{cm}$$

Measurement Results

The frequency response of the accelerometer Type 8307 is shown in Fig.3. It has a resonance at 75 kHz and at 50 kHz it has a level 3 dB higher than the flat response at lower frequencies.

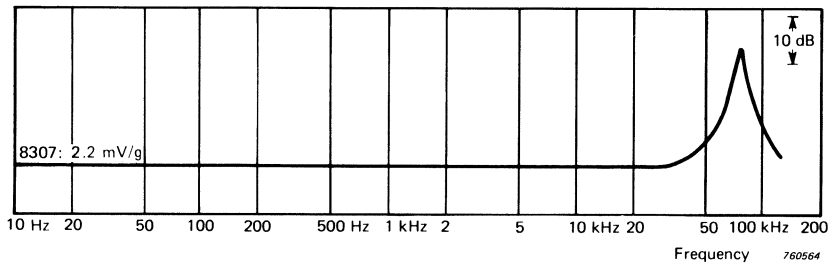

Fig.3. Frequency Response of Accelerometer Type 8307

Figs.4— 8 illustrate frequency response curves of different cartridges obtained with the use of test records Types QR 2009/QR 2010 and the accelerometer excitation method. On account of the suspension resonance of the accelerometer on foam rubber, all of the curves obtained with the use of the accelerometer show a peak around 700 Hz, the frequency depending on the accelerometer mass and stiffness of foam rubber. Besides, the response obtained with the use of the accelerometer will have a level approximately 3 dB higher than the true level at 50 kHz.

Fig.4 shows the response curves of a stereophonic pick-up Ortofon SL 15 MT obtained with test record QR 2010 and the accelerometer. It can be seen that there is very good agreement between the curves up to 20 kHz. Above 20 kHz the response curve obtained with the test record falls off rather sharply on account of the compliance of the test record indicating a rather high tip mass of the pick-up.

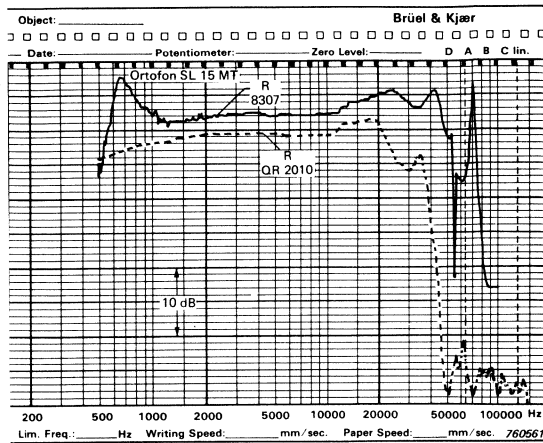

Fig.4. Frequency Response of Stereophonic Pick-up Ortofon SL 15 MT

Fig. 5 shows corresponding curves of a quadrophonic pick-up MMC 6000. In this case very good agreement between the curves is obtained in the frequency region 1500 Hz — 45 kHz. The compliance of the test record is not noticeable on the curve indicating an extremely low tip mass of the pick-up.

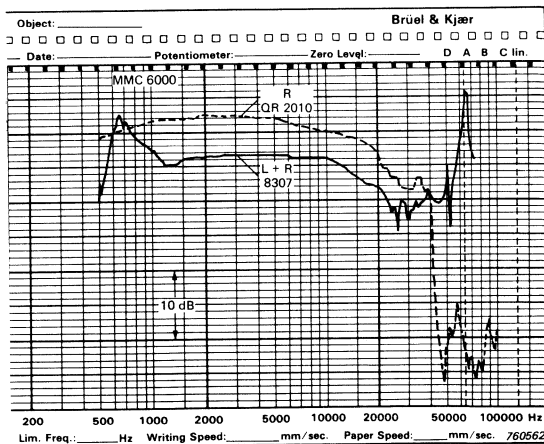

Fig.5. Frequency Response of Quadrophonic Pick-up MMC 6000

Fig.6 shows response curves of a stereophonic pick-up M 15 Super E. It should be noted that the resonance frequency on the curve obtained with the accelerometer is higher than on the curve obtained with the test record.

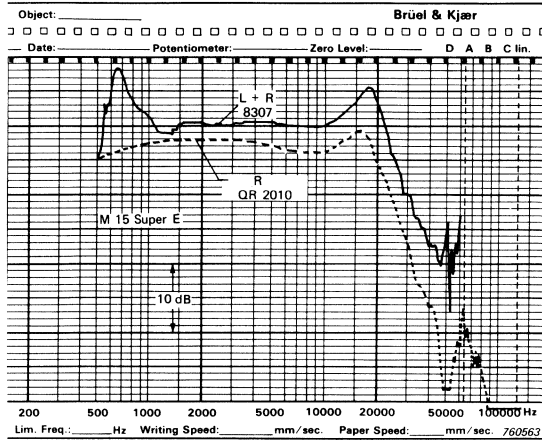

Fig.6. Frequency Response of Stereophonic Pick-up M 15 Super E

The response curves shown in Fig.7 are of a quadrophonic pick-up AT 20 SLa. The compliance of the record is visible above 45 kHz.

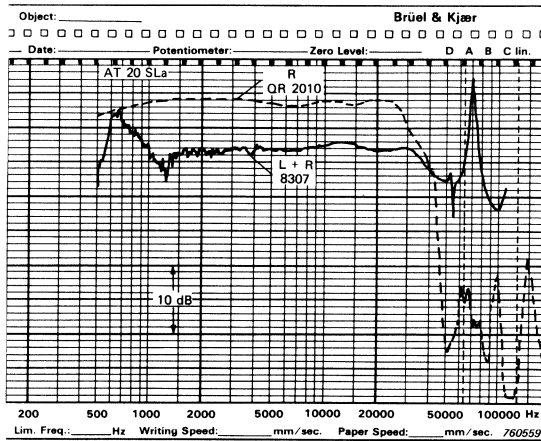

Fig.7. Frequency Response of Quadrophonic Pick-up AT 20 SLa

Fig.8 shows response curves of a monophonic pick-up Ortofon Type A. The resonance due to the interaction between the tip mass and the record material can be seen clearly and is almost one octave lower than that obtained with the accelerometer.

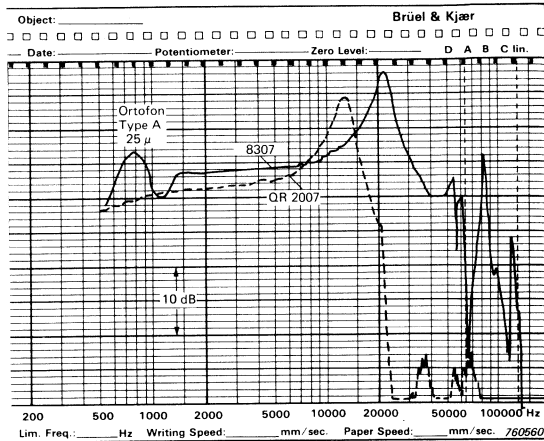

Fig.8. Frequency Response of Monophonic Pick-up Ortofon Type A

Finally, the accelerometer was fed with musical signals and the pick-up signal was led to a stereo-amplifier. The reproduction was excellent except for the missing bass on account of the 12 dB/oct. roll-off below the suspension resonance due to the accelerometer mass and foam rubber stiffness.

Conclusion

The advantages of using accelerometer as an exciter for gramophone cartridges for obtaining their high frequency response are quite obvious. By this method frequency responses in the frequency range 1 — 50 kHz can be obtained. The errors normally encountered with the conventional methods of using test records, such as the geometrical and deformation of the groove walls can be avoided as well as the effects of the compliance of the record material. Furthermore, not only is impulse testing possible by this method, but also absolute calibration of the pick-ups.

APPENDIX

Impulse Testing of Gramophone Cartridges

Fig.A1 shows a measurement set-up for impulse testing of pick-ups. Since a high voltage is often required, a Power Amplifier Type 2713 has been inserted after a square wave generator. After the integration network, a frequency weighting giving a notch at 75 kHz should be inserted to counteract the accelerometer resonance.

If some of the harmonics of the square wave are close to the accelerometer resonance, the square wave will be distorted depending on the pick-up sensitivity at this frequency. After the integration network, a frequency weighting giving a notch at 75 kHz should be inserted to counteract the accelerometer resonance.

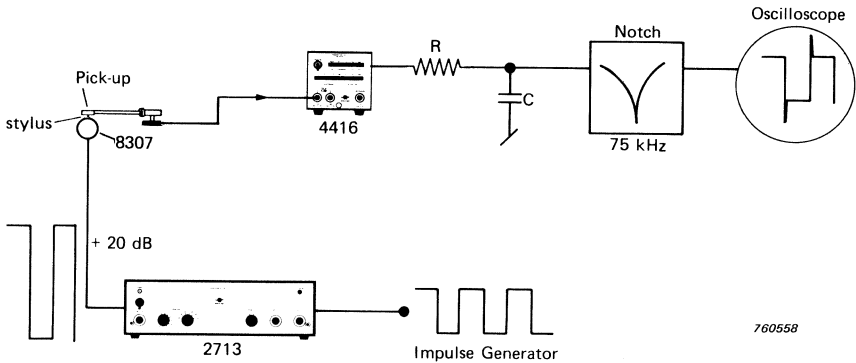
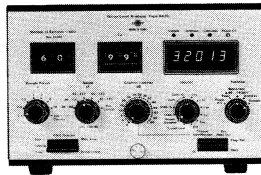

Fig.A1. Measurement arrangement for impulse testing of gramophone cartridges

News from the Factory

Noise Level Analyzer Type 4426

Evaluation of community noise ratings require statistical level analysis of noise signals by which the levels exceeded for certain percentages of the measurement period are determined. These level values, which are normally measured using the A weighting network, are termed L_N where N is the percentage of the measurement period. For example, L_{10} and L_{90} are used for evaluation of Traffic Noise Index (TNI) and Noise Pollution Level (NPL) while L_1 and L_{99} give indication of the peak values and background noise level respectively.



The Noise Level Analyzer Type 4426 can not only measure L_{10} , L_{50} and L_{90} but also L_{eq} and L_N where N could be any integer between 1 and 99. Further, it can process histograms, which show the level distribution directly and cumulative distribution plots showing levels exceeded for N% of the measurement period, either in number of samples or in percentages. The calculations can be based either on instantaneous levels or on max. values during the sampling intervals for measurements in accordance with the German standard "Takt Maximalpegelverfahren". Up to 65000 samples can be collected with a choice of sampling intervals between 0,1 s and 10 s giving a maximum measurement period of approx. 180 hours.

The analyzer, when connected with a B & K condenser microphone and preamplifier also functions as a precision sound level meter with a built-in A weighting network and the standardized time constants "Fast" "Slow" and "Impulse". For analysis of tape recorded signals or signals from a sound level meter, the A weighting network can be by-passed by using the linear AC and DC inputs.

This instrument, which makes extensive use of modern digital techniques, divides the input signal into 256 level classes over a dynamic range of 64 dB, each level class thus being 1/4 dB wide. Depending on the microphone used, the total measuring range is from 26 dBA to 140 dBA. The RMS detector has a very high crest factor capability, ranging from 3 at maximum reading and increasing linearly up to more than 50 at or below 24 dB under maximum reading.

Any of the measured or calculated values may be displayed on the 5 digit display at any time during or after the measurement period, without interference with the measurement or memory contents.

Analogue outputs to Level Recorder Type 2306 provide for automatic recording of the cumulative distribution and probability distribution curves as well as the instantaneous sound level or any L_N value as a function of time, thus enabling the location of noise events in time. The 4426 is delivered with a fully interfaced digital output for connection to an alphanumeric printer. The built-in clock in the printer may be set to initiate periodic print-outs of the data as the measurement progresses. The print-outs are clearly labelled including the time of day.

The instrument is truly portable as it can be powered by Ni Cd-cells or a 12 V car battery. A plug-in line power supply is also available.

Sine Generator Type 1023

The Sine Generator Type 1023, operating on the Heterodyne principle, generates sinusoidal signals from 10 Hz to 20 kHz in one continuous range. Frequency modulation of the output signal (which is often used in building acoustic measurements for preventing the generation of standing waves) is also possible.

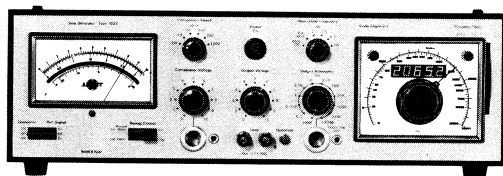

In addition to the analogue frequency scale, the instrument is equipped with an accurate frequency counter with a five digit frequency display with counting times 0,1 s or 1 s. Both linear and logarithmic frequency sweeps can be carried out either manually or remotely via a mechani-

cal drive or an electrical signal. It can thus be synchronized with a Level Recorder Type 2305 or 2307 for obtaining a graphic record on frequency calibrated paper.

The built-in voltmeter is furnished with linear and dB scales and indicates the voltage either at the attenuator output or at the load output. 0,1 mV to 10V RMS full scale is available at the attenuator output. The load output can supply 0 to 10V RMS at 700mA RMS giving a maximum power output of 7W which is sufficient to drive either a Standing Wave Apparatus Type 4002, a Hearing Aid Test Box Type 4212, an Artificial Voice Type 4219 or a Mini-Shaker Type 4810.

A built-in compressor facility (dynamic range > 60dB) enables the output voltage to be controlled, such that the output from a loudspeaker or a vibration exciter, for example, can be maintained at a constant level as the frequency is swept. The compressor gives no regulation error for fixed frequency outputs, regardless of the degree of compression.

Tuning signals for connection to Heterodyne Slave Filter Type 2020 are included for carrying out constant bandwidth analysis. With the inclusion of Tracking Frequency Multiplier Type 1901 in the set-up, automatic harmonic analysis can also be performed.

For production testing and inspection of amplifiers, tape recorders, filters, loudspeakers and other electroacoustic devices, the generator can sweep automatically with an Audio Frequency Response Tracer Type 4712.

400°C Balanced Accelerometer Type 8308

Strong electromagnetic fields, nuclear radiation and high temperatures are some factors that present a rather hostile environment for vibration measurement and monitoring. However, the problem of electromagnetic interference in the transmission line between the accelerometer and preamplifier can be largely overcome by the adoption of a balanced output from an accelerometer. Hence both the poles of the piezoelectric element of this accelerometer Type 8308 are insulated with the same capacitance and high resistance with respect to its case, which also prevents ground loop problems. The signal from the accelerometer is transmitted via a twisted shielded pair whereby any noise pick-up will be essentially equal on both the wires. In a suitable differential preamplifier, such as the B & K Type 2634 the two noise signals are subtracted and thus largely cancelled.

The use of a specially formulated Piezoelectric ceramic permits operation of this accelerometer in an environment with continuous temperatures up to 400°C (750°F). With good air circulation around the accelerometer, flange temperatures well in excess of this figure can be permitted.

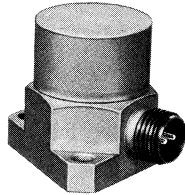

Furthermore, this accelerometer can tolerate accumulated radiation doses of hundreds of MRads and in the order of 10^{18} to 10^{19} thermal neutrons/cm² flux density. (At dose rates of approx. 1 MRad/hour and 10^{12} n/cm² per second.)

The Uni-Gain[®] feature of this accelerometer (charge sensitivity $1 \text{ pC/ms}^{-2} \pm 2\%$) gives a very close interchangeability tolerance which allows replacement without altering the sensitivity of the associated measuring instrumentation. The casing of the accelerometer is made from a high quality stainless steel type AISI 316 and is hermetically sealed to prevent the ingress of contaminants such as humidity, oil, fuel etc. The flange dimensions are in accordance with the three hole fixing described in the ARINC Characteristic 544.

Each individual accelerometer is subjected to a thorough aging, stabilizing and quality testing procedure, making it ideal for vibration measurement and monitoring over long term in severe environmental conditions, for example, on aircraft engines in service, industrial machinery, steam and gas turbines, power station alternators and nuclear reactors.

Miniature Hydrophone Type 8103

The Miniature Hydrophone Type 8103 is a small size piezoelectric transducer for making underwater sound measurements over wide dynamic and frequency ranges. It has a high sensitivity relative to its size (nominal voltage sensitivity $30 \mu\text{V/Pa}$) and covers a frequency range from 0,1 Hz to 200 kHz. The high frequency response of the hydrophone is particularly useful in recording a variety of dynamic pressure phenomena which are typically found in free-field blast measurements and in the investigation of the pressure time profiles of shock waves. Also for



recording marine animal noises and investigation of the pressure distribution pattern in ultrasonic cleaning baths, the high frequency characteristics are valuable. Besides, the hydrophone can be used as a sound source under water, both for measurement and reciprocity calibration purposes.

In very high humidity and polluted atmospheres and at pressure levels up to 4×10^6 Pa (conditions completely alien to normal microphones) the hydrophone can be used as a robust economically priced outdoor microphone with a -3 dB frequency limit of 15 kHz.

The hydrophone is equipped with a 6 m long double shielded, low noise integral cable that terminates with a standard miniature coaxial plug.

1/2" Condenser Microphones Types 4165 and 4166

In applications where 1" microphones introduce intolerable disturbances in the sound field, the 1/2" Microphones Types 4165 and 4166 can be used, as they have sensitivities similar to that of 1" cartridges. They are therefore useful for general and low level sound meas-



urements. Both of them have quartz covered diaphragms and are back-vented for use with the 1/2" Dehumidifier UA 0308 for measurements in humid environments. Type 4165 which fulfils the IEC R179 standard is for free-field measurements and has a flat frequency response within ± 2 dB from 3 Hz to 20 kHz (0° incidence). Type 4166 which fulfils ANSI S1.4-1971, Type 1, standard is for random incidence and has a flat response within ± 1 dB in the frequency range 3 Hz to 8 kHz.